

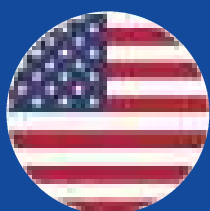

CATALOGUE

Ed.4.0





LOGICWALL 04

Wall mounted inverter

LOGICBOARD 08

On board inverter

LOGICBOARD POOL 10

On board inverter for swimming pool pumps

LOGICTWIN 12

Wall mounted inverter for booster sets

LOGICPANEL 14

Wall mounted panel for booster sets

LOGICPANEL SEWAGE 16

Wall mounted panel for waste water lifting stations



LOGICPRESS SET Wall mounted inverter	18	LOGICPRESS PLUS Wall mounted inverter	24
LOGICPRESS On board inverter	20	LOGICPRESS 3PHASE On board inverter	26
LOGICPRESS AF On board inverter for swimming pool pumps	22	CONTROLPRES On board inverter for swimming pool pumps	28
		CONTROLPRES 3PHASE Wall mounted inverter for booster sets	30
		LOGICFLOW Wall mounted panel for booster sets	32

* Trevitech reserves the right to make changes without prior notice.



Made in Italy

LOGICWALL / WALL PRO

WALL MOUNTED INVERTER

The M version can control single-phase pumps or 230V three-phase pumps.

Can be wall-mounted or installed directly on the pipe system (M and T series).

Varies the number of motor revolutions of the pump depending to the water withdrawal from the system in order to maintain constant pressure and flow rate.

Allows to regulate the system pressure and the restart pump pressure.

Stops the pump in case of water shortage and protects it from dry running.

Equipped with automatic restart in case of failure and anti-jamming function.

Ensures energy saving.

Can be installed on surface and submersible pumps.

Standardly supplied with stainless steel pressure sensor.

CONTROL PANEL

Setting up and starting the LOGICWALL is easy and intuitive thanks to the large and bright LCD display that shows the information and the keyboard that allows to quickly enter and change the operating parameters of the pump.



To save energy, the display turns off one minute after the last operation. To turn the display back on, simply press any button on the keypad.

The LEDs indicating the main phases of the device's operation remain always lit to allow the user to always have the status of the system under control.

Data transmission with NFC technology.

Download our APP Trevitech from Google play or App store and place the mobile phone near the icon NFC to transfer the information from the inverter to your smartphone.



INSTALLATION AND STARTUP

Install the device on the wall or directly on the system pipe.

Connect the supplied pressure sensor, make electrical connections and energize.

Provide the use of an expansion tank sized to the hydraulic characteristics of the system.

Follow the instructions on the screen of the device to start the pump.

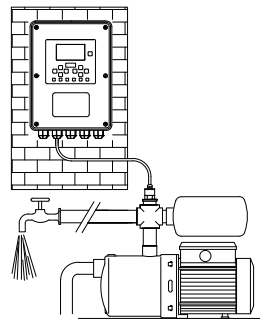

OPERATING MODE

The Logicwall has three selectable operating modes:

- **RESIDENTIAL** Standard operation. Ideal for domestic installations and pressure booster sets.
- **IRRIGATION** Allows to set 3 different operating and restart pressures of the pump. Ideal for residential, public irrigation and agriculture.
- **SWIMMING POOL/INDUSTRY** Allows to set up to 3 different fixed pump operating speeds. Ideal for residential, public swimming pools and industry.

AUTOMATIC RESTARTS

In case of stopping due to a water shortage, the device will automatically make 10 double attempts to rearm over the 24 hours following the failure, each lasting approximately 5 seconds to allow the pump and the system to reload if possible.

The user can try to rearm the device at any time by pressing the Restart button.

ANTI-JAMMING FUNCTION

If for any reason the pump remains idle for 24 consecutive hours, the device will start the pump for about 5 seconds.

BOOSTER SETS

INSTALLATION AND STARTUP

Connect the devices together using the serial ports.

Program the device selected as Master and the slaves following the instructions on the display.

OPERATION

The device starts and stops the pumps according to the opening and closing of the uses. It is possible to operate the device in different operating modes:

- **Duty/Assist:** The pumps alternate at each start and work simultaneously when needed.
- **Duty/Stand-by:** The pumps alternate at each start but never work at the same time.
- **Only pump 1 o 2:** Only the pump selected by the user works.

PUMPS ALTERNATION DURING CONTINUOUS OPERATION

If for any reason one or more pumps are working continuously, in order to guarantee uniform wear of the pumps, every sixty minutes of continuous operation of a pump, a forced exchange will be made with another pump on stand-by.

The changeover respects the alternating sequence of all the devices.

VARIABLE MASTER

In case of malfunctioning of the Master device, the system will transfer the operation to the Slave device immediately following the Master. If the original Master device has been reset, it will automatically be reintegrated into the system.

AUTOMATIC RESTARTS E ANTI-JAMMING FUNCTION

For details refer to the paragraph above.

OPTIONALS

- Alarm panel.

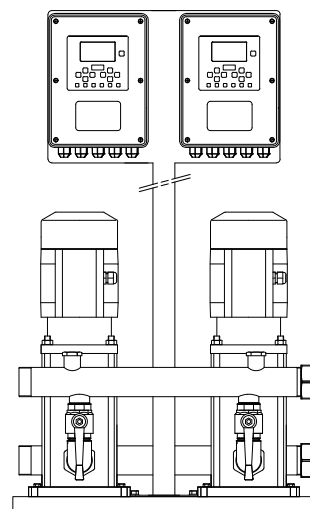

TECHNICAL FEATURES

LOGICWALL

	SINGLE-PHASE /		THREE-PHASE	THREE-PHASE /	
	MODELS	M 8,5	M 11	M 13	T 6
Mains voltage		1 ~ 230 Vac	1 ~ 230 Vac	1 ~ 230 Vac	3 ~ 400 Vac
Acceptable voltage fluctuations		+/- 15%	+/- 15%	+/- 15%	+/- 15%
Frequency (automatic recognition)		50 / 60 Hz	50 / 60 Hz	50 / 60 Hz	50 / 60 Hz
Single-phase pump motor		1 ~ 230 V	1 ~ 230 V	1 ~ 230 V	-
Three-phase pump motor		3 ~ 230 V Δ	3 ~ 230 V Δ	3 ~ 230 V Δ	3 ~ 400 V Y
Maximum pump motor current		8,5 A	11 A	13 A	6 A
Maximum single-phase pump motor power		1,1 kW - 1,5 HP	1,5 kW - 2 HP	2,2 kW - 3 HP	-
Maximum three-phase pump motor power		1,9 kW - 2,5 HP	2,2 kW - 3 HP	3 kW - 4 HP	2,2 kW - 3 HP
Motor soft start		Yes	Yes	Yes	Yes
Motor cable length up to 80 m		Yes	Yes	Yes	Yes
Maximum operating pressure		362 psi	362 psi	362 psi	362 psi
Adjustable system pressure		29 ÷ 362 psi	29 ÷ 362 psi	29 ÷ 362 psi	29 ÷ 362 psi
Adjustable restart pressure		14,5 ÷ 348 psi	14,5 ÷ 348 psi	14,5 ÷ 348 psi	14,5 ÷ 348 psi
Adjustable minimum flow		Yes	Yes	Yes	Yes
Maximum operating temperature		122 °C	122 °C	122 °C	122 °C
Protection degree		Type 4	Type 4	Type 4	Type 4
Digital manometer		Yes	Yes	Yes	Yes
Digital ammeter		Yes	Yes	Yes	Yes
Dry running protection		Yes	Yes	Yes	Yes
Automatic restart		Yes	Yes	Yes	Yes
Anti-jamming function		Yes	Yes	Yes	Yes
Protection fuse		Yes	Yes	Yes	Yes
Irrigation mode (double pressure)		Yes	Yes	Yes	Yes
Pool/Industry mode (fixed speed)		Yes	Yes	Yes	Yes
Short-circuit protection between phases		Yes	Yes	Yes	Yes
Short-circuit protection between phases and earth		Yes	Yes	Yes	Yes
Amperometric protection		Yes	Yes	Yes	Yes
Voltage surge protection		Yes	Yes	Yes	Yes
Over-temperature protection		Yes	Yes	Yes	Yes
Pressure sensor fault detection		Yes	Yes	Yes	Yes
Flow switch connection		Yes	Yes	Yes	Yes
BMS protocol connection		Yes	Yes	Yes	Yes
Integrated NFC data transfer system		Yes	Yes	Yes	Yes
Connection for float switch and level probe		Yes	Yes	Yes	Yes
Remote ON/OFF connection		Yes	Yes	Yes	Yes
Remote "Pump on" connection		Yes	Yes	Yes	Yes
Remote alarm connection		Yes	Yes	Yes	Yes
Communication between devices		Yes	Yes	Yes	Yes
Overall dimensions (L x H x W) and weight		7,9 x 10,8 x 4,9 Inch - 18 lbs			7,9 x 10,8 x 4,9 Inch - 18 lbs

* Device protection degree Type 4, cooling fan Type 1.

Note: The minimum and maximum values of the system pressure and the restart pressure vary according to the pressure sensor used.
Three-phase 230V versions with power up to 27 Ampere are available on request.



Made in Italy

LOGICBOARD

ON BOARD INVERTER

Varies the number of motor revolutions of the pump depending to the water withdrawal from the system in order to maintain constant pressure and flow rate.

Allows to adjust the system pressure and the restart pump pressure.

Stops the pump in case of water shortage and protects it from dry running.

Equipped with automatic reset in case of failure and anti-jamming function.

Ensures energy saving.

Standarly supplied with stainless steel pressure sensor.

TECHNICAL FEATURES

	M11	T6
Mains voltage	230 Vac	400 Vac
Acceptable voltage fluctuation	+/- 10%	+/- 10%
Frequency	50/60 Hz	50/60 Hz
Current max	11 A	6 A
Power max	2,2 kW - 3 HP (3~ 230 V)	2,2 kW - 3 HP
Protection degree	Type 4	Type 4
Operating temperature max	140 °F	140 °F
Overall dimensions	6,7x9,4x4,3 Inch - 5,5 lbs	6,7x9,4x4,3 Inch - 5,5 lbs



CONTROL PANEL

Setting up and starting the device is easy and intuitive thanks to the large and bright color LCD display that shows all the information, and the keyboard that allows you to quickly enter and change the operating parameters of the pump.

To save energy, the display turns off one minute after the last operation. To turn the display back on, simply press any button on the keypad.

INSTALLATION AND STARTUP

Install the device directly on the motor.

Connect the supplied pressure sensor, make electrical connections and energize.

Provide the use of an expansion tank sized on the hydraulic characteristics of the system.

Follow the instructions on the screen of the device to start the pump.

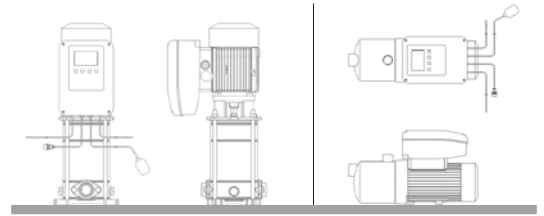

OPERATION

The device starts and stops the pumps depending on the opening and closing of the outlets.

The device can operate in different operating modes:

- **RESIDENTIAL** Standard operation. Ideal for domestic installations and booster sets.
- **FIX SPEED** Allows to set up a fix speed operation of the pump.
- **RWS (Rain Water System)** Allows to drive the RWS valve to change from rain water to mains supply.

AUTOMATIC RESTARTS

In case of stopping due to a water shortage, the device will automatically make 10 double attempts to rearm over the 24 hours following the failure, each lasting approximately 5 seconds to allow the pump and the system to reload if possible. The user can try to rearm the device at any time by pressing the Restart button.

ANTI-JAMMING FUNCTION

If for any reason the pump remains idle for 24 consecutive hours, the device will start the pump for about 5 seconds.

BOOSTER SETS

INSTALLATION AND STARTUP

Connect the devices together using the serial ports.

Program the device selected as Master and the slaves following the instructions on the display.

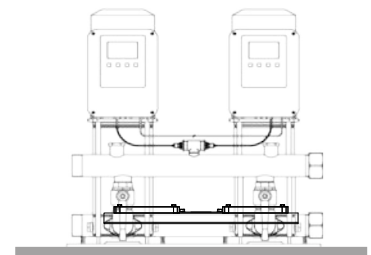

OPERATION

The device starts and stops the pumps according to the opening and closing of the outlets.

It is possible operate the device in different operating modes:

- **Duty/Assist:** The pumps alternate at each start and work simultaneously when needed.
- **Duty/Stand-by:** The pumps alternate at each start but never work at the same time.
- **Only pump 1 o 2:** Only the pump selected by the user works.

PUMPS ALTERNATION DURING CONTINUOUS OPERATION

If for any reason one or more pumps are working continuously, in order to guarantee uniform wear of the pumps, every sixty minutes of continuous operation of a pump, a forced exchange will be made with another pump on stand-by.

The changeover respects the alternating sequence of all the devices.

VARIABLE MASTER

In case of malfunctioning of the Master device, the system will transfer the operation to the Slave device immediately following the Master. If the original Master device has been reset, it will automatically be reintegrated into the system.

AUTOMATIC RESTARTS E ANTI-JAMMING FUNCTION

For details refer to the paragraph above.

OPTIONALS

- MODBUS Connection for external remote communication module.
- BLUETOOTH Connection for Bluetooth module.
- SND SENSOR Operating with temperature or pressure differential.
- WALL FIX Wall mounting bracket.
- Alarm panel.



Made in Italy

LOGICBOARD-POOL

ON BOARD INVERTER FOR SWIMMING POOL PUMPS

Equipped with daily and weekly timers.

Allows manual operating speed selection.

Allows the management of auxiliary systems.

Equipped with backwash function.

Guarantees energy savings.

TECHNICAL FEATURES

	M11	T6
Mains voltage	230 Vac	400 Vac
Acceptable voltage fluctuation	+/- 10%	+/- 10%
Frequency	50/60 Hz	50/6
Current max	11 A	6 A
Power max	2,2 kW - 3 HP (3~)	2,2 kW - 3 HP
Protection degree	Type 4	Type 4
Operating temperature max	140 °F	140 °F
Overall dimensions	6,7x9,4x4,3 Inch - 5,5 lbs	6,7x9,4x4,3 Inch - 5,5 lbs



CONTROL PANEL

Setting up and starting the device is easy and intuitive thanks to the large and bright color LCD display that shows all the information, and the keyboard that allows to quickly enter and change the operating parameters of the pump.

To save energy, the display turns off one minute after the last operation. To turn the display back on, simply press any button on the keypad.

INSTALLATION AND STARTUP

Install the device directly on the motor.

Connect auxiliary systems if needed.

Energize the device, set the timer and working speeds.

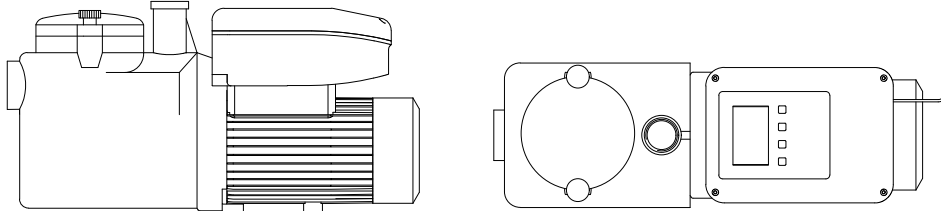

OPERATION

The device can operate in different operating modes:

- TIMER** Standard operation, the device works according to set times and speeds. The Time function allows to select two types of clock:
- WEEKLY** It allows to set up to 4 working time frames, each with its own operating speed.
 - DAILY** Allows to set for each day of the week up to 4 working time frames, each with its own working speed.
- MANUAL** Allows to set up to 4 working speeds that can be manually selected via a button.
- BACKWASH** Enable this function only when cleaning the filters. The device makes the pump work at maximum speed and disables auxiliary contacts.

AUXILIARY CONTACTS

It is possible to enable up to 4 auxiliary contacts and set their operating times according to the WEEKLY or DAILY logic. This function allows to manage the start-up and shutdown at the desired times of the following systems:

- Saline Chlorine generator
- PH dosing pump
- Pool lights
- Other equipment

There is also a contact to signal pump failure.

OPTIONALS

- MODBUS Connection for external remote communication module.
- BLUETOOTH Connection for Bluetooth module.
- WALL FIX Wall mounting bracket.
- Alarm panel.



Made in Italy

LOGICTWIN

WALL MOUNTED INVERTER FOR BOOSTER SETS

Equipped with 2 inverters each dedicated to a single pump of the booster set.

Varies the number of motor revolutions of the pump depending to the water withdrawal from the system in order to maintain constant pressure and flow rate.

Allows to regulate the system pressure and the restart pump pressure.

Stops the pumps in case of water shortage and protects them from dry running.

Equipped with automatic restart in case of failure and anti-jamming function.

Ensures energy saving.

Standardly supplied with a stainless steel pressure sensor.

TECHNICAL FEATURES

	TWIN M11	TWIN T6
Mains voltage	230 Vac	400 Vac
Acceptable voltage fluctuation	+/- 10%	+/- 10%
Frequency	50/60 Hz	50/60 Hz
Current max	11 A	6 A
Power max for each pump single-phase	1,5 kW - 2 HP	---
Power max for each pump three-phase	1,5 kW - 2 HP (3 ~ 230 V Δ)	2,2 kW - 3 HP
Protection degree	Type 4	Type 4
Operating temperature max	140 °F	140 °F
Overall dimensions	7,9 x 10,8 x 4,9 inch - 18 lbs	7,9 x 10,8 x 4,9 inch - 18 lbs



CONTROL PANEL

The device is equipped with latest generation Touch Screen display.

Thanks to the larger and higher resolution screen, reading the parameters and managing all the functions of the device are further simplified.

Simply touch the screen to start/stop the pumps or to carry out any further operation.

The display turns off two minutes after the last operation. To turn the display back on, simply touch the display.

INSTALLATION AND STARTUP

Install the device directly on the booster set or on the wall.

Connect the supplied pressure sensor, make electrical connections and energize.

Provide the use of an expansion tank sized to the hydraulic characteristics of the system.

Follow the instructions on the screen of the device to start the pump.

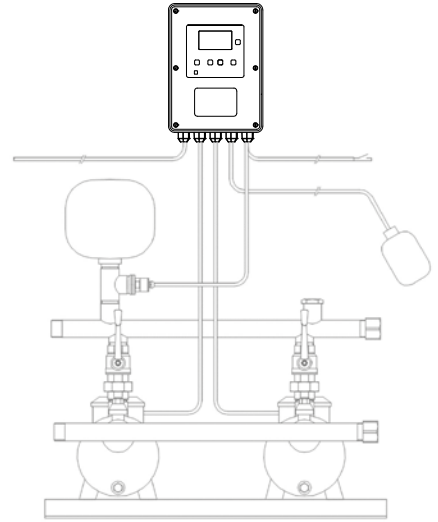

OPERATION

The device starts and stops the pumps depending on the opening and closing of the outlets.

The device can operate in different operating modes:

- **Duty/Assist:** The pumps alternate at each start and work simultaneously when needed.
- **Duty/Stand-by:** The pumps alternate at each start but never work at the same time.
- **Only pump 1 o 2:** Only the pump selected by the user works.

PUMPS ALTERNATION DURING CONTINUOUS OPERATION

If, for any reason, one or more pumps are working continuously, in order to guarantee uniform wear of the pumps, every sixty minutes of continuous operation of a pump a forced exchange will be made with stand-by pump.

The changeover respects the alternating sequence of all the pumps.

AUTOMATIC RESTARTS

In case of stopping due to a water shortage, the device will automatically make 10 double attempts to rearm over the 24 hours following the failure, each lasting approximately 5 seconds to allow the pump and the system to reload if possible. The user can try to rearm the device at any time by pressing the Restart button.

ANTI-JAMMING FUNCTION

If for any reason the pump remains idle for 24 consecutive hours, the device will start the pump for about 5 seconds.

VARIABLE MASTER

In case of malfunctioning of the Master device, the system will transfer the operation to the Slave device immediately following the Master. If the original Master device has been reset, it will automatically be reintegrated into the system.

OPTIONALS

- MODBUS Connection for external remote communication module.
- BLUETOOTH Connection for Bluetooth module.
- Alarm panel.



Made in Italy

LOGICPANEL

WALL MOUNTED PANEL FOR BOOSTER SETS

Allows to adjust the cut-in and cut-out pressure of the pumps.

It guarantees the alternation of the pumps at each start.

Stops the pumps in case of water shortage and protects them from dry running.

Equipped with automatic reset in case of failure and anti-jamming function.

Allows the connection of electric safety float and a remote contact.

It can also be used to operate a single pump.

TECHNICAL FEATURES

	Single-phase		Three-phase	
	M2HP	M3HP	T4HP	T5.5HP
Mains voltage	115/230 Vac	115/230 Vac	400 Vac	400 Vac
Acceptable voltage fluctuation	+/- 10%	+/- 10%	+/- 10%	+/- 10%
Frequency	50/60 Hz	50/60 Hz	50/60 Hz	50/60 Hz
Current max	10 A	16 A	8 A	10 A
Power max for each pump at 115V	0,75 kW (1 HP)	1,1 kW (1,5 HP)	----	----
Power max for each pump at 230V	1,5 kW (2 HP)	2,2 kW (3 HP)	----	----
Power max for each pump at 400V	----	----	3 kW (4 HP)	4 kW (5,5 HP)
Protection degree	Type 4	Type 4	Type 4	Type 4
Operating temperature max	140 °F	140 °F	140 °F	140 °F
Overall dimensions	8,7x6,7x2,8 Inch - 1,10 lbs	8,7x6,7x2,8 Inch - 1,10 lbs	8,7x6,7x2,8 Inch - 1,10 lbs	8,7x6,7x2,8 Inch - 1,10 lbs



CONTROL PANEL

Setting up and starting the device is easy and intuitive thanks to the large and bright LCD display that shows all the information, and the keyboard that allows you to quickly enter and change the operating parameters of the pumps.

To save energy, the display turns off one minute after the last operation. To turn the display back on, simply press any button on the keypad.

The LEDs indicating the main phases of the device's operation remain lit to allow the user to always have the status of the system under control.

INSTALLATION AND STARTUP

Install the device directly on the booster set or on the wall.

Connect the pumps and the supplied ultrasonic sensor to the device.

Energize and set the operating levels and select the desired working mode.

Provide the use of an expansion tank sized to the hydraulic characteristics of the system.

Follow the instructions on the screen of the device to start the pump.

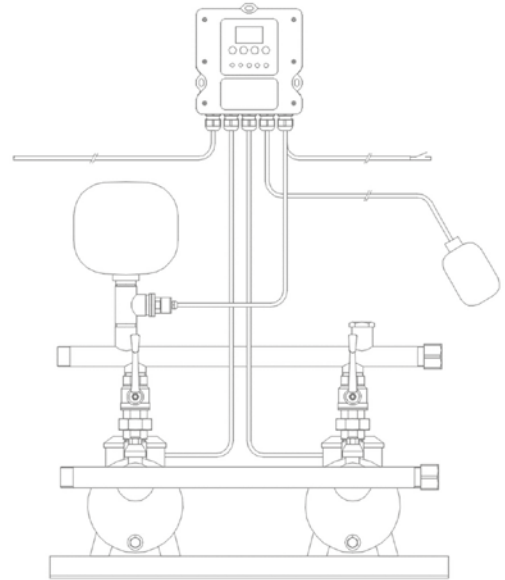

OPERATION

The device starts and stops the pumps depending on the opening and closing of the outlets. The device can operate in different operating modes:

- **Duty/Assist:** The pumps alternate at each start and work simultaneously when needed.
- **Duty/Stand-by:** The pumps alternate at each start but never work at the same time.
- **Only pump 1 o 2:** Only the pump selected by the user works.

PUMPS ALTERNATION DURING CONTINUOUS OPERATION

In the event that, for any reason, one or more pumps work continuously, to ensure uniform wear of the group's pumps, every sixty minutes of continuous operation of one pump, a forced change is performed with another at rest.

The changeover respects the alternation sequence of the pumps.

AUTOMATIC RESTARTS

In case of stopping due to a water shortage, the device will automatically make 10 double attempts to rearm over the 24 hours following the failure, each lasting approximately 5 seconds to allow the pump and the system to reload if possible. The user can try to rearm the device at any time by pressing the Restart button.

ANTI-JAMMING FUNCTION

If for any reason the pump remains idle for 24 consecutive hours, the device will start the pump for about 5 seconds.

SPECIAL VERSIONS

- **THERMO** Version equipped with temperature sensor to start the pumps according to set temperatures. Can work for both cooling and heating. Can be integrated with the Timer version.
- **TIMER** Version with programmable weekly clock. Allows to set up to 4 different daily starts for each day of the week.
- **RWS** Version for the management of rainwater collection systems.

OPTIONALS

- Alarm panel.



Made in Italy

LOGICPANEL-SEWAGE

WALL MOUNTED PANEL FOR WASTE WATER LIFTING STATIONS

Allows to set the start and stop levels of each pump.

Guarantees the alternation of the pumps at each start.

Allows real-time display of the water level.

Stops the pumps in case of water shortage and protects them from dry running.

Allows to set the level of alarm intervention.

Allows the connection of electric emergency float and a remote contact.

Can also be used to operate a single pump.

Equipped with ultrasonic sensor set.

TECHNICAL FEATURES

	Single-phase		Three-phase	
	M2HP	M3HP	T4HP	T5.5HP
Mains voltage	115/230 Vac	115/230 Vac	400 Vac	400 Vac
Acceptable voltage fluctuation	+/- 10%	+/- 10%	+/- 10%	+/- 10%
Frequency	50/60 Hz	50/60 Hz	50/60 Hz	50/60 Hz
Current max	10 A	16 A	8 A	10 A
Power max for each pump at 115V	0,75 kW (1 HP)	1,1 kW (1,5 HP)	----	----
Power max for each pump at 230V	1,5 kW (2 HP)	2,2 kW (3 HP)	----	----
Power max for each pump at 400V	----	----	3 kW (4 HP)	4 kW (5,5 HP)
Protection degree	Type 4	Type 4	Type 4	Type 4
Operating temperature max	140 °F	140 °F	140 °F	140 °F
Overall dimensions	8,7x6,7x2,8 Inch - 1,10 lbs	8,7x6,7x2,8 Inch - 1,10 lbs	8,7x6,7x2,8 Inch - 1,10 lbs	8,7x6,7x2,8 Inch - 1,10 lbs



CONTROL PANEL

Setting up and starting the device is easy and intuitive thanks to the large and bright LCD display that shows all the information, and the keyboard that allows you to quickly enter and change the operating parameters of the pump.

To save energy, the display turns off one minute after the last operation. To turn the display back on, simply press any button on the keypad.

The LEDs indicating the main phases of the device's operation remain always lit to allow the user to always have the status of the system under control.

INSTALLATION AND STARTUP

Install the device near the tank or on the wall.

Connect the pumps and the supplied ultrasonic sensor to the device.

Energize and set the operating levels and select the desired working mode.

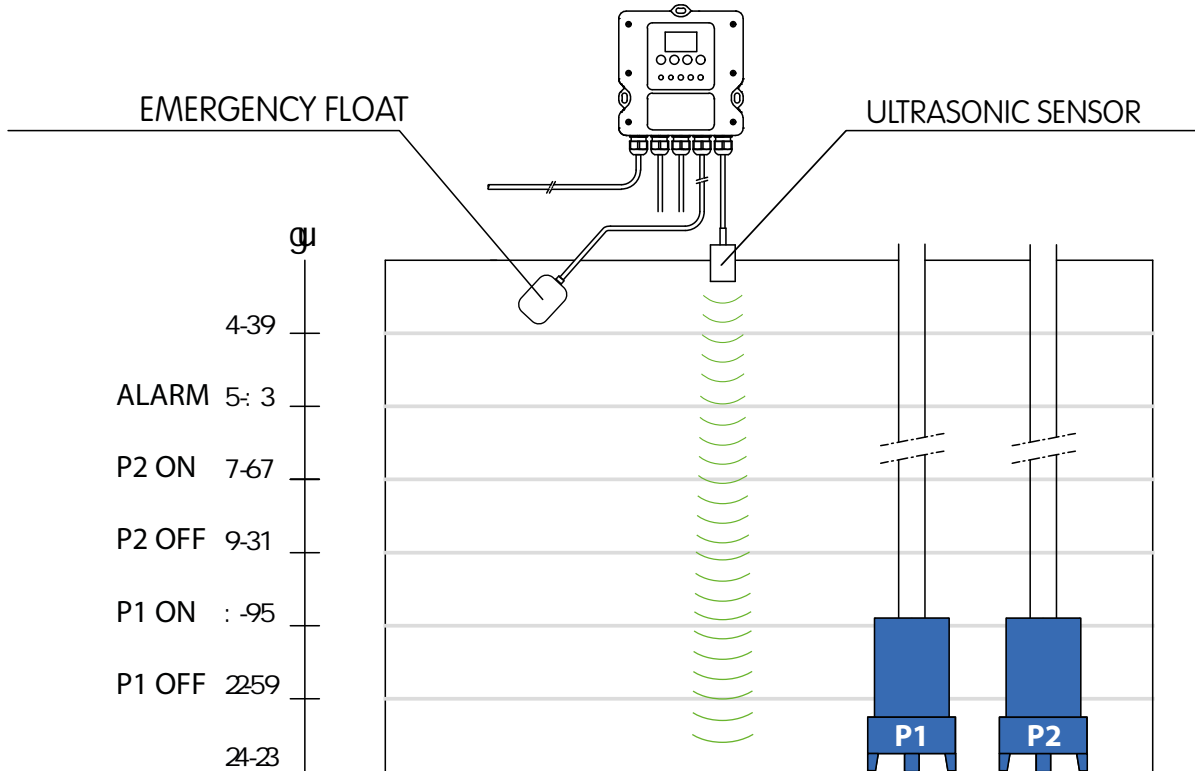

OPERATION

The device starts and stops the pump (or pumps) depending on water level set for each pump. It is also possible to set the level of alarm intervention. The device can operate in different operating modes:

- **Duty/Assist:** The pumps alternate at each start and work simultaneously when needed.
- **Duty/Stand-by:** The pumps alternate at each start but never work at the same time.
- **Only pump 1 o 2:** Only the pump selected by the user works.

EMERGENCY FLOAT

In the event that the ultrasonic sensor fails, the water level will activate the emergency float that will start both pumps and signal the alarm.

PUMPS ALTERNATION DURING CONTINUOUS OPERATION

If, for any reason, one or more pumps are working continuously, in order to guarantee uniform wear of the pumps, every sixty minutes of continuous operation of a pump a forced exchange will be made with stand-by pump.

The changeover respects the alternating sequence of all the pumps.

ANTI-JAMMING FUNCTION

If for any reason the pump remains idle for 24 consecutive hours, the device will start the pump for about 5 seconds.

OPTIONALS

- Alarm panel.



Made in Italy
 PATENTED

LOGICPRESS SET

PRESSURE SWITCH WITH SELECTABLE RESTART PRESSURES

Allows to set the restart pressure value of the pump.

Starts and stops the pump depending on opening and closing of the outlets.

Stops the pump in case of water shortage and protects it from dry running.

Equipped with automatic rearms in case of failure and an anti-jamming function.

Can be installed on surface and submersible pumps.

No need for an expansion tank, check valve, filter or fittings.





Maintenance free.

TECHNICAL FEATURES

	LOGICPRESS SET	LOGICPRESS SET 115 V
Single-phase mains voltage	230 Vac	230 Vac
Acceptable voltage fluctuation	+/- 10%	+/- 10%
Frequency	50/60 Hz	50/60 Hz
Current max	12 A	12 A
Power max	1,5 kW (2 HP)	0,75 kW (1 HP)
Adjustable restart pressure	22-29-36 psi	22-29-36 psi
Protection degree	Type 4	Type 4
Operating pressure max	174 psi	174 psi
Operating temperature max	55 °C - 131 °F	55 °C - 131 °F
Minimum flow	~0,26 l/gpm	~0,26 l/gpm
Male connections	1" npt	1" npt

CONTROL PANEL

SIGNALING OF THE WORKING PHASES AND ANOMALIES

	POWER ON	Green LED on	Device energized
	PUMP ON	Yellow LED on	Pump running
	FAILURE	Red LED blinking	Water shortage
	RESTART	Button	Reset after failure

INSTALLATION AND STARTUP

The device can be installed directly on the pump or between the pump and the first tap.

Make all the electrical connections and energize.

From now on, the device will turn the pump on and off depending on the opening and closing of the tap.

In case of a temporary blackout, the device will automatically rearm once the electricity returns.

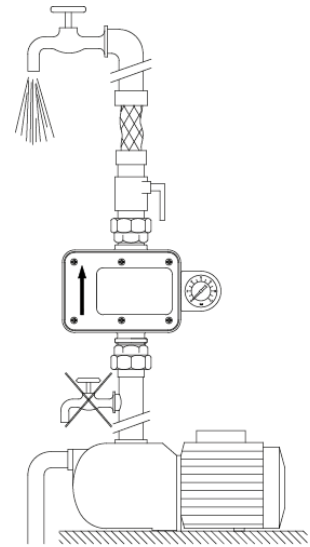

SELECTION OF THE DEVICE WITH THE CORRECT RESTART VALUE

To change the restart value, press and hold the **Set** button for three seconds (see image). Repeat the operation until the green LED is on the desired restart value. Select the correct restart value suitable to the characteristics of the system.



36	Green LED on	Restart 36 psi
29	Green LED on	Restart 29 psi
22	Green LED on	Restart 22 psi
Set	Button	Restart selection

RESTART PRESSURE	22 psi	29 psi	36 psi
FLOORS NUMBER	5	6	8
BUILDING HEIGHT (H)	50 feet	65 feet	80 feet
MAX PUMP PRESSURE	min 42 psi	min 50 psi	min 58 psi

AUTOMATIC RESTARTS

In case of stopping due to a water shortage, the device will automatically make 10 double attempts to rearm over the 24 hours following the failure, each lasting approximately 5 seconds to allow the pump and the system to reload if possible. The user can try to rearm the device at any time by pressing the Restart button.

ANTI-JAMMING FUNCTION

If for any reason the pump remains idle for 24 consecutive hours, the device will start the pump for about 5 seconds.

OPTIONALS

- Orange blue version (see photo), other colors on request.
- Manometer (0-174 psi range) factory mounted or supplied separately.
- GasOil version, suitable for use with petroleum and other chemicals.





Made in Italy
PATENTED

LOGICPRESS

PRESSURE FLOW SWITCH DEVICE WITH AUTOMATIC REARMS

Can be energized with either 115 Vac or 230 Vac.

Starts and stops the pump depending on opening and closing of the outlets.

Stops the pump in case of water shortage and protects it from dry running.

Equipped with automatic restarts in case of failure and anti-jamming function.

Can be installed on surface and submersible pumps.

No need for an expansion tank, check valve, filter or fittings.





Maintenance free.

TECHNICAL FEATURES

	LOGICPRESS
Single-phase mains voltage	115/230 Vac
Acceptable voltage fluctuation	+/- 10%
Frequency	50/60 Hz
Current max at 115 V	16 A
Current max at 230 V	12 A
Power max at 115V	0,75 kW (1 HP)
Power max at 230V	1,5 kW (2 HP)
Protection degree	Type 4
Operating pressure max	174 psi
Operating temperature max	55 °C / 131 °F
Minimum flow	~0,26 gpm
Male connections	1" npt

CONTROL PANEL

SIGNALING OF THE WORKING PHASES AND ANOMALIES

	POWER ON Green LED on	Device energized
	PUMP ON Yellow LED on	Pump running
	FAILURE Red LED blinking	Water shortage
	RESTART Button	Reset after failure

INSTALLATION AND STARTUP

The device can be installed directly on the pump or between the pump and the first tap.

Make all the electrical connections and energize.



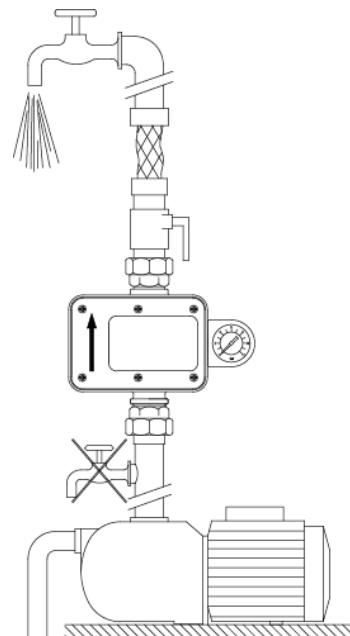

From now on, the device will turn the pump on and off depending on the opening and closing of the tap.

In case of a temporary blackout, the device will automatically rearm once the electricity returns.



SELECTION OF THE DEVICE WITH THE CORRECT RESTART VALUE

Refer to the following table to choose the device with the correct restart value suitable to the characteristics of the system. Standard restart value is 22 psi. On request, restart values different from the standard are available as indicated in the table.

 RESTART PRESSURE	12 psi	17 psi	22 psi	32 psi	42 psi
 FLOORS NUMBER	2	4	5	7	10
 BUILDING HEIGHT (H)	25 feet	40 feet	50 feet	70 feet	90 feet
 MAX PUMP PRESSURE	min 29 psi	min 36 psi	min 42 psi	min 55 psi	min 65 psi

AUTOMATIC RESTARTS

In case of stopping due to a water shortage, the device will automatically make 10 double attempts to rearm over the 24 hours following the failure, each lasting approximately 5 seconds to allow the pump and the system to reload if possible. The user can try to rearm the device at any time by pressing the Restart button.

ANTI-JAMMING FUNCTION

If for any reason the pump remains idle for 24 consecutive hours, the device will start the pump for about 5 seconds.

OPTIONALS

- Blue/orange version (see picture), other colors on demand.
- Manometer (0-174 psi range) factory mounted or supplied separately.
- GasOil version, suitable for use with petroleum and other chemicals.





Made in Italy
PATENTED

LOGICPRESS AF

PRESSURE FLOW SWITCH WITH ANTI-FLOODING FUNCTION

Allows to set the maximum time of continuous operation of the pump.

Starts and stops the pump depending on opening and closing of the outlets.

Stops the pump in case of water shortage and protects it from dry running.

Equipped with automatic restart in case of failure and anti-jamming function.

Can be installed on surface and submersible pumps.

No need for an expansion tank, check valve, filter or fittings.





Maintenance free.

TECHNICAL FEATURES

	LOGICPRESS AF 230 V	LOGICPRESS AF 115 V
Single-phase mains voltage	230 Vac	115 Vac
Acceptable voltage fluctuation	+/- 10%	+/- 10%
Frequency	50/60 Hz	50/60 Hz
Current max	12 A	16 A
Power max	1,5 kW (2 HP)	0,75 kW (1 HP)
Protection degree	Type 4	Type 4
Operating pressure max	174 psi	174 psi
Operating temperature max	55 °C - 131 °F	55 °C - 131 °F
Minimum flow	~0,26 gpm	~0,26 gpm
Male connections	1" npt	1" npt

CONTROL PANEL

SIGNALING OF THE WORKING PHASES AND ANOMALIES

	POWER ON	Green LED on	Device energized
	PUMP ON	Yellow LED on	Pump running
	FAILURE	Flashing red LED	Water shortage
		Fixed red LED	Intervention for max. time
	RESTART	Button	Reset after failure

INSTALLATION AND STARTUP

The device can be installed directly on the pump or between the pump and the first tap.

Make all the electrical connections and energize.

From now on, the device will turn the pump on and off depending on the opening and closing of the tap.

In case of a temporary blackout, the device will automatically rearm once the electricity returns.

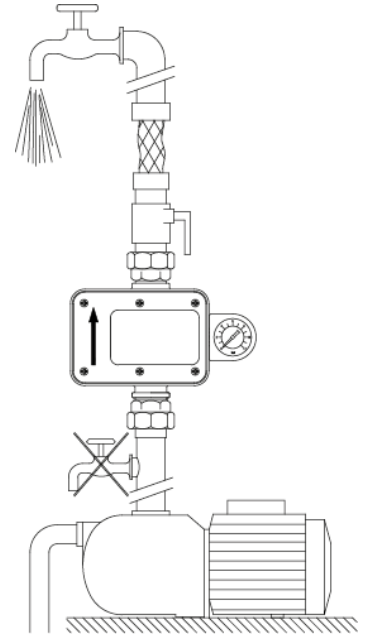

SELECTION OF THE DEVICE WITH THE CORRECT RESTART VALUE

Refer to the following table to choose the device with the correct restart value suitable to the characteristics of the system. Standard restart value is 22 psi. On request, restart values different from the standard are available as indicated in the table.

RESTART PRESSURE	12 psi	17 psi	22 psi	32 psi	42 psi
FLOORS NUMBER	2	4	5	7	10
BUILDING HEIGHT [H]	25 feet	40 feet	50 feet	70 feet	90 feet
MAX PUMP PRESSURE	min 29 psi	min 36 psi	min 42 psi	min 55 psi	min 65 psi

ANTI-FLOODING FUNCTION

This function allows to set the maximum continuous running time after which the unit stops the pump. In this way, in the event of a pipe rupture, the device will stop the pump once the set time has been reached, limiting the damage caused by continuous water leakage. This function is therefore particularly suitable for second homes, garden irrigation and all poorly supervised applications.

It is possible to select a maximum operating time from those shown in the following table:



Press and hold the "Set Time" key to set the maximum pump time on. Each combination of LEDs corresponds to the Maximum Pump-on time indicated in the table. If the continuous running time is exceeded, the device stops the pump and the red Failure light turns on. To restore normal operation, press the "Restart" key.

AUTOMATIC RESTARTS

In case of stopping due to a water shortage, the device will automatically make 10 double attempts to rearm over the 24 hours following the failure, each lasting approximately 5 seconds to allow the pump and the system to reload if possible. The user can try to rearm the device at any time by pressing the Restart button.

ANTI-JAMMING FUNCTION

If for any reason the pump remains idle for 24 consecutive hours, the device will start the pump for about 5 seconds.

OPTIONALS

- Manometer (0-174 psi range) factory mounted or supplied separately.
- Version 115 Vac.
- Blu/Orange version.
- GasOil version - suitable for use with petroleum and other chemicals.



Made in Italy

LOGICPRESS PLUS

PRESSURE FLOW SWITCH WITH 1"1/4 CONNECTIONS

Can be energized with either 115 Vac or 230 Vac.

Starts and stops the pump depending on opening and closing of the outlets.

It has 1"1/4 male connections to guarantee a higher flow rate.

Stops the pump in case of water shortage and protects it from dry running.

Equipped with automatic restarts in case of failure and anti-jamming function.

No need for an expansion tank, check valve, filter or fittings.

Can be installed on surface and submersible pumps up to 3 HP.





Maintenance free.

TECHNICAL FEATURES

	LOGICPRESS PLUS	LOGICPRESS PLUS R	LOGICPRESS 24V
Single-phase mains voltage	115/230 Vac	115/230 Vac	24V DC
Acceptable voltage fluctuation	+/- 10%	+/- 10%	+/- 10%
Frequency	50/60 Hz	50/60 Hz	50/60 Hz
Current max	20 A	20 A	20 A
Power max at 115V	1,1 kW (1,5 HP)	1,1 kW (1,5 HP)	—
Power max at 230V	2,2 kW (3 HP)	2,2 kW (3 HP)	—
Power max at 24V DC	—	—	0,37 kW (0,5 HP)
Protection degree	Type 4	Type 4	Type 4
Operating pressure max	174 psi	174 psi	174 psi
Operating temperature max	65 °C / 149 °F	65 °C / 149 °F	65 °C / 149 °F
Minimum flow	~0,26 gpm	~0,26 gpm	~0,26 gpm
Male connections	mod. MCAF 1"npt mod. MCBF 1 1/4"npt	mod. MCAF 1"npt mod. MCBF 1 1/4"npt	mod. MCAF 1"npt mod. MCBF 1 1/4"npt

CONTROL PANEL

SIGNALING OF THE WORKING PHASES AND ANOMALIES

	POWER ON Green LED on	Device energized
	PUMP ON Yellow LED on	Pump running
	FAILURE Red LED blinking	Water shortage
	RESTART Button	Reset after failure

INSTALLATION AND STARTUP

The device can be installed directly on the pump or between the pump and the first tap.

Make all the electrical connections and energize.

From now on, the device will turn the pump on and off depending on the opening and closing of the tap.

In case of a temporary blackout, the device will automatically rearm once the electricity returns.

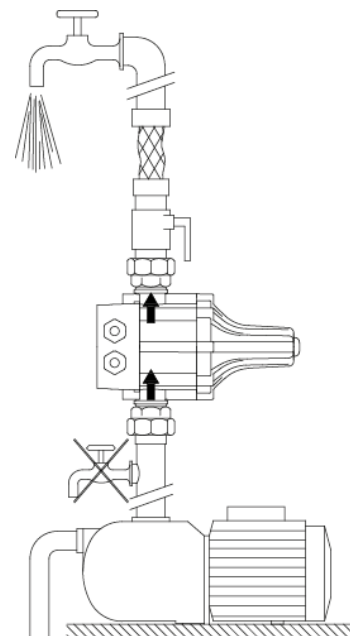

SELECTION OF THE DEVICE WITH THE CORRECT RESTART VALUE

Refer to the following table to choose the device with the correct restart value suitable to the characteristics of the system. Standard restart value is 22 psi. On request, restart values different from the standard are available as indicated in the table.

RESTART PRESSURE	17 psi	22 psi	32 psi	42 psi	58 psi
FLOORS NUMBER	4	5	7	10	13
BUILDING HEIGHT (H)	40 feet	50 feet	70 feet	90 feet	130 feet
MAX PUMP PRESSURE	min 36 psi	min 42 psi	min 55 psi	min 65 psi	min 80 psi

AUTOMATIC RESTARTS

In case of stopping due to a water shortage, the device will automatically make 10 double attempts to rearm over the 24 hours following the failure, each lasting approximately 5 seconds to allow the pump and the system to reload if possible. The user can try to rearm the device at any time by pressing the Restart button.

ANTI-JAMMING FUNCTION

If for any reason the pump remains idle for 24 consecutive hours, the device will start the pump for about 5 seconds.

LOGICPRESS *PLUS R*

It differs from the LOGICPRESS PLUS only in the hydraulic part, modified to allow the adjustment of the restart value and for the presence, as standard, of the pressure gauge.

SETTING THE RESTART VALUE

Set the desired restart value by turning the screw on the back of the unit. Turn clockwise to increase restart pressure value and counterclockwise to decrease restart pressure value (see fig. 1).

For a correct regulation of the restart value, follow the table below.

RESTART PRESSURE	22 psi	29 psi	36 psi	42 psi
FLOORS NUMBER	5	6	8	10
BUILDING HEIGHT (H)	50 feet	65 feet	80 feet	90 feet
MAX PUMP PRESSURE	min 42 psi	min 50 psi	min 58 psi	min 65 psi



FIG.1

LOGICPRESS *PLUS 24V*

24 Vdc version ideal for use on campers, industrial vehicles, boats, photovoltaic systems, etc.

OPTIONALS

- GasOil version suitable for use with petroleum and other chemicals.
- 12 Vdc version.



Made in Italy

PATENTED

LOGICPRESS 3PHASE

THREE-PHASE PRESSURE FLOW SWITCH WITH 1"1/4 CONNECTIONS

Three-phase power supply 400 Vac.

Starts and stops the pump depending on opening and closing of the outlets.

It has 1"1/4 male connections to guarantee a higher flow rate.

Stops the pump in case of water shortage and protects it from dry running.

Equipped with automatic restart in case of failure and anti-jamming function.

No need for an expansion tank, check valve, filter or fittings.

Can be installed on surface and submersible pumps up to 3 HP.





Maintenance free.

TECHNICAL FEATURES

	LOGICPRESS 3PHASE	LOGICPRESS 3PHASE PLUS
Three-phase mains voltage	400 Vac	230 Vac / 400 Vac
Three-phase pump motor voltage	400 V Y	230 V Δ / 400 V Y
Acceptable voltage fluctuation	+/- 10%	+/- 10%
Frequency	50/60 Hz	50/60 Hz
Current max	6 A	6 A
Power max at 230V	—	1,1 kW (1,5 HP)
Power max at 400V	2,2 kW (3 HP)	2,2 kW (3 HP)
Protection degree	Type 4	Type 4
Operating pressure max	174 psi	174 psi
Operating temperature max	50 °C / 122 °F	50 °C / 122 °F
Minimum flow	~0,26 gpm	~0,26 gpm
Male connections	1 1/4" npt	1 1/4" npt
Standard equipped cables	H07RN-F 4Gx1,5 mm ²	H07RN-F 4Gx1,5 mm ²

CONTROL PANEL

SIGNALING OF THE WORKING PHASES AND ANOMALIES

	POWER ON Green LED on	Device energized
	PUMP ON Yellow LED on	Pump running
	FAILURE Red LED blinking	Water shortage
	RESTART Button	Reset after failure

INSTALLATION AND STARTUP

The device can be installed directly on the pump or between the pump and the first tap.

Make all the electrical connections and energize.



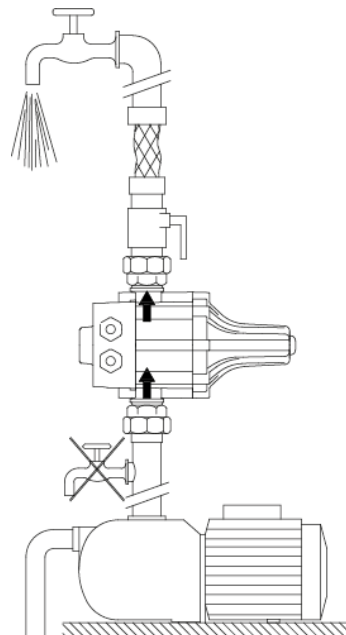

From now on, the device will turn the pump on and off depending on the opening and closing of the tap.

In case of a temporary blackout, the device will automatically rearm once the electricity returns.



SELECTION OF THE DEVICE WITH THE CORRECT RESTART VALUE

Refer to the following table to choose the device with the correct restart value suitable to the characteristics of the system. Standard restart value is 22 psi. On request, restart values different from the standard are available as indicated in the table.

 RESTART PRESSURE	17 psi	22 psi	32 psi	42 psi	58 psi
 FLOORS NUMBER	4	5	7	10	13
 BUILDING HEIGHT (H)	40 feet	50 feet	70 feet	90 feet	130 feet
 MAX PUMP PRESSURE	min 36 psi	min 42 psi	min 55 psi	min 65 psi	min 80 psi

AUTOMATIC RESTARTS

In case of stopping due to a water shortage, the device will automatically make 10 double attempts to rearm over the 24 hours following the failure, each lasting approximately 5 seconds to allow the pump and the system to reload if possible. The user can try to rearm the device at any time by pressing the Restart button.

ANTI-JAMMING FUNCTION

If for any reason the pump remains idle for 24 consecutive hours, the device will start the pump for about 5 seconds.

LOGICPRESS *3PHASE PLUS*

It differs from the LOGICPRESS 3PHASE due to the presence of electrical protections for the motor. It can be powered with either 230 or 400V three-phase voltage.

PROTEZIONE CONTRO L'INVERSIONE DEL SENSO DI ROTAZIONE DEL MOTORE

In the event of accidental inversion of a power phase, the appliance recognizes the anomaly and automatically maintains the correct direction of rotation of the motor as set and verified during installation.

PROTECTION AGAINST INVERSION OF THE DIRECTION OF ROTATION OF THE MOTOR

In the event of a missing phase in power supply, the device detects the fault and prevents the pump from starting.

OPTIONALS

- Pressure gauge.
- GasOil version - suitable for use with petroleum and other chemicals.



Made in Italy

LOGICONTROL

PRESSURE FLOW SWITCH WITH ADJUSTABLE WORKING PRESSURE

Can be energized with either 115 Vac or 230 Vac.

Starts and stops the pump depending on opening and closing of the outlets.

Allows to reduce the maximum pressure of the pump and to set the working pressure.

Stops the pump in case of water shortage and protects it from dry running.

Equipped with automatic restart in case of failure and anti-jamming function.

No need for an expansion tank, check valve, filter or fittings.

Can be installed on surface and submersible pumps up to 3 HP.





Maintenance free.

TECHNICAL FEATURES

	LOGICONTROL
Single-phase mains voltage	115/230 Vac
Acceptable voltage fluctuation	+/- 10%
Frequency	50/60 Hz
Current max	20 A
Power max at 115V	1,1 kW (1,5 HP)
Power max at 230V	2,2 kW (3 HP)
Protection degree	Type 4
Operating pressure max	174 psi
Operating temperature max	65 °C / 149 °F
Minimum flow	~0,26 gpm
Pressure regulating range	42 - 94 psi
Male connections	1 1/4" npt

CONTROL PANEL

SIGNALING OF THE WORKING PHASES AND ANOMALIES

	POWER ON Green LED on	Device energized
	PUMP ON Yellow LED on	Pump running
	FAILURE Red LED blinking	Water shortage
	RESTART Button	Reset after failure

INSTALLATION AND STARTUP

The device can be installed directly on the pump or between the pump and the first tap.

Make all the electrical connections and energize.

From now on, the device will turn the pump on and off depending on the opening and closing of the tap.

In case of a temporary blackout, the device will automatically rearm once the electricity returns.

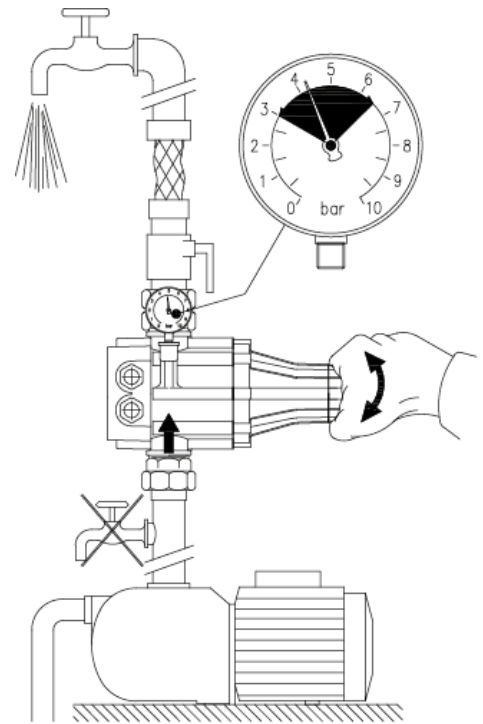

REGULATION OF THE WORKING PRESSURE

To set the pressure to the desired value, turn the knob on the rear of the device clockwise to increase the pressure and counterclockwise to decrease it (adjustment range from 42 to 94 psi). The restart value is directly proportional to the regulated pressure (see table).

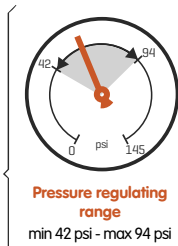
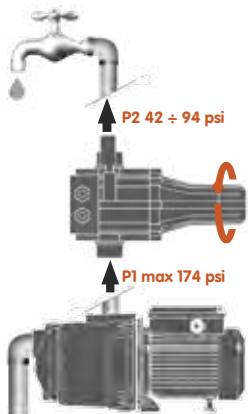

SET PRESSURE	42 psi	50 psi	58 psi	65 psi	72 psi	80 psi	87 psi	94 psi
RESTART PRESSURE	17 psi	22 psi	29 psi	36 psi	42 psi	50 psi	58 psi	65 psi
FLOORS NUMBER	4	5	6	8	10	11	13	15
BUILDING HEIGHT [H]	40 feet	50 feet	65 feet	80 feet	90 feet	115 feet	130 feet	145 feet
MAX PUMP PRESSURE	min 65 psi	min 72 psi	min 80 psi	min 87 psi	min 94 psi	min 101 psi	min 109 psi	min 116 psi

AUTOMATIC RESTARTS

In case of stopping due to a water shortage, the device will automatically make 10 double attempts to rearm over the 24 hours following the failure, each lasting approximately 5 seconds to allow the pump and the system to reload if possible. The user can try to rearm the device at any time by pressing the Restart button.

ANTI-JAMMING FUNCTION

If for any reason the pump remains idle for 24 consecutive hours, the device will start the pump for about 5 seconds.



Made in Italy
PATENTED

LOGICONTROL 3PHASE

THREE-PHASE PRESSURE FLOW SWITCH WITH ADJUSTABLE WORKING PRESSURE

Three-phase power supply 400 Vac.

Starts and stops the pump depending on opening and closing of the outlets.

Allows to reduce the maximum pressure of the pump and to set the working pressure.

It has 1"1/4 male connections to guarantee a higher flow rate.

Stops the pump in case of water shortage and protects it from dry running.

Equipped with automatic restart in case of failure and anti-jamming function.

No need for an expansion tank, check valve, filter or fittings.

Can be installed on surface and submersible pumps up to 3 HP.





Maintenance free.

TECHNICAL FEATURES

	LOGICONTROL 3PHASE	LOGICONTROL 3PHASE PLUS
Three-phase mains voltage	400 Vac	230 Vac / 400 Vac
Three-phase pump motor voltage	400 V Y	230 V Δ / 400 V Y
Acceptable voltage fluctuation	+/- 10%	+/- 10%
Frequency	50/60 Hz	50/60 Hz
Current max	6 A	6 A
Power max at 230V	—	1,1 kW (1,5 HP)
Power max at 400V	2,2 kW (3 HP)	2,2 kW (3 HP)
Protection degree	Type 4	Type 4
Operating pressure max	174 psi	174 psi
Operating temperature max	50 °C / 122 °F	50 °C / 122 °F
Minimum flow	~0,26 gpm	~0,26 gpm
Pressure regulating range	42 - 94 psi	42 -94 psi
Male connections	1 1/4" npt	1 1/4" npt
Standard equipped cables	H07RN-F 4Gx1,5 mm ²	H07RN-F 4Gx1,5 mm ²

CONTROL PANEL

SIGNALING OF THE WORKING PHASES AND ANOMALIES

	POWER ON Green LED on	Device energized
	PUMP ON Yellow LED on	Pump running
	FAILURE Red LED blinking	Water shortage
	RESTART Button	Reset after failure

INSTALLATION AND STARTUP

The device can be installed directly on the pump or between the pump and the first tap.

Make all the electrical connections and energize.

From now on, the device will turn the pump on and off depending on the opening and closing of the tap.



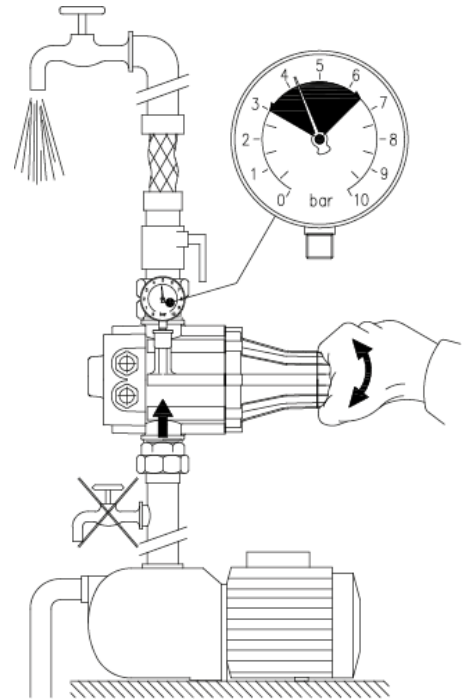

In case of a temporary blackout, the device will automatically rearm once the electricity returns.

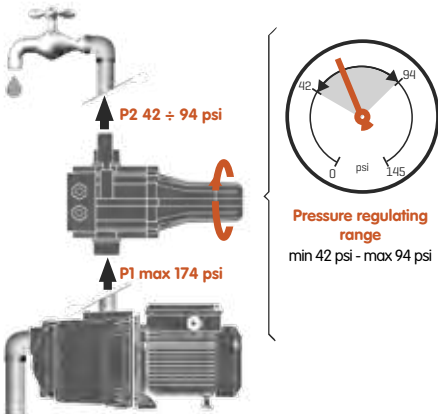

REGULATION OF THE WORKING PRESSURE

To set the pressure to the desired value, turn the knob on the rear of the device clockwise to increase the pressure and counterclockwise to decrease it (adjustment range from 42 to 94 psi). The restart value is directly proportional to the regulated pressure (see table).



 SET PRESSURE	42 psi	50 psi	58 psi	65 psi	72 psi	80 psi	87 psi	94 psi
 RESTART PRESSURE	17 psi	22 psi	29 psi	36 psi	42 psi	50 psi	58 psi	65 psi
 FLOORS NUMBER	4	5	6	8	10	11	13	15
 BUILDING HEIGHT (H)	40 feet	50 feet	65 feet	80 feet	90 feet	115 feet	130 feet	145 feet
 MAX PUMP PRESSURE	min 65 psi	min 72 psi	min 80 psi	min 87 psi	min 94 psi	min 101 psi	min 109 psi	min 116 psi

AUTOMATIC RESTARTS

In case of stopping due to a water shortage, the device will automatically make 10 double attempts to rearm over the 24 hours following the failure, each lasting approximately 5 seconds to allow the pump and the system to reload if possible. The user can try to rearm the device at any time by pressing the Restart button.

ANTI-JAMMING FUNCTION

If for any reason the pump remains idle for 24 consecutive hours, the device will start the pump for about 5 seconds.

LOGICONTROL *3PHASE PLUS*

It differs from LOGICONTROL 3PHASE for the presence of electrical protections for the motor.

It can be powered with either 230 or 400 V three-phase voltage.

PROTECTION AGAINST INVERSION OF THE DIRECTION OF ROTATION OF THE MOTOR

In case of accidental inversion of a phase in power supply, the device detects the anomaly and automatically maintains the correct direction of rotation of the motor as set and verified during installation.

PROTECTION AGAINST A MISSING PHASE IN POWER SUPPLY

In the event of a missing phase in power supply, the device detects the fault and prevents the pump from starting.



Made in Italy

LOGICFLOW

FLWSWITCH

Can be energized with either 115 Vac or 230 Vac.

Starts and stops the pump depending on opening and closing of the outlets.

Stops the pump in case of water shortage and protects it from dry running.



Maintenance free.

TECHNICAL FEATURES

	LOGICFLOW	LOGICFLOW <i>PLUS</i>
Single-phase mains voltage	115/230 Vac	115/230 Vac
Acceptable voltage fluctuation	+/- 10%	+/- 10%
Frequency	50/60 Hz	50/60 Hz
Current max at 115V	14 A	14 A
Current max at 230V	10 A	10 A
Power max at 115V	0,55 kW (0,75 HP)	0,55 kW (0,75 HP)
Power max at 230V	1,1 kW (1,5 HP)	1,1 kW (1,5 HP)
Protection degree	Type 4	Type 4
Operating pressure max	232 psi	232 psi
Operating temperature max	55 °C / 131 °F	55 °C / 131 °F
Minimum flow	~0,13 gpm	~0,13 gpm
Male connections	1" npt	1" npt

CONTROL PANEL

SIGNALING OF THE WORKING PHASES AND ANOMALIES

	POWER ON	Green LED on	Device energized
	PUMP ON	Yellow LED on	Pump running
	RESTART	Button	Reset after failure

INSTALLATION AND STARTUP

The device can be installed directly on the pump or between the pump and the first tap.

Make all the electrical connections and energize.

In order to operate it requires a minimum flow that passes through it when a tap of the system is opened.

For this reason, the device and the system taps must be installed lower than the tank.

Starts and stops the pump depending on the opening and closing of the taps.

In case of a temporary blackout, the device will automatically rearm once the electricity returns.

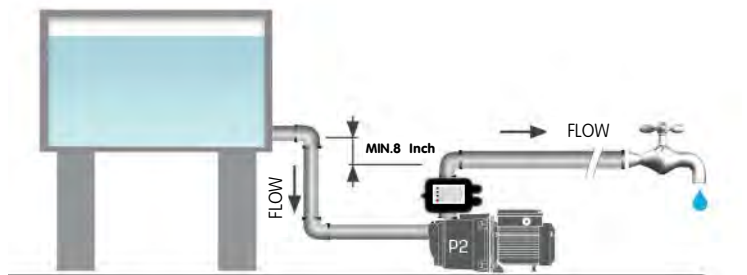
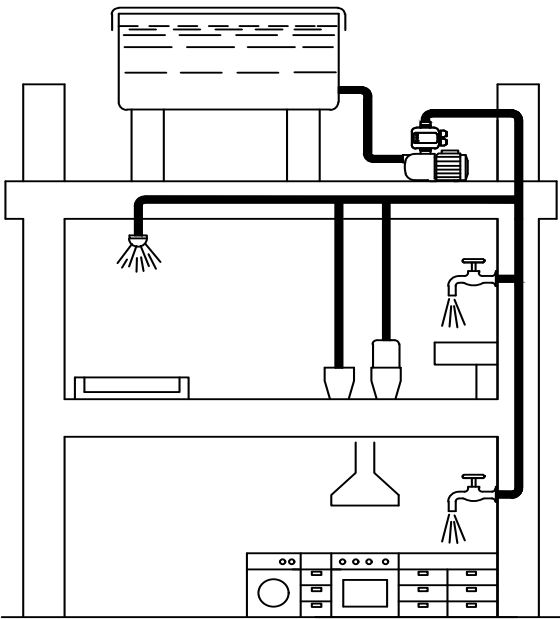

LOGICFLOW *PLUS*

The PLUS version is different from the standard LOGICFLOW due to the presence of automatic rearms and the anti-jamming function.

The device automatically starts the pump for about 7 seconds every 30 minutes for 6 hours.

The first start takes place 30 minutes after the last pump stop.

The device also automatically starts the pump for about 7 seconds every 24 hours (antijamming function).

The pump is started 24 hours after the last pump stop.

This model is ideal for the direct provisioning from the water mains in the event of frequent interruptions in the water supply service.

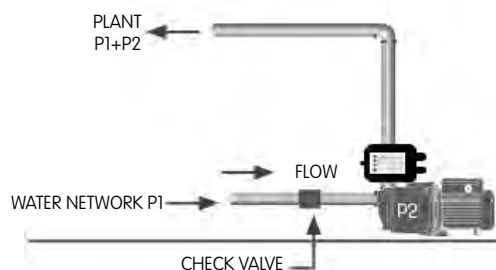

QUALITY MARKS AND CERTIFICATIONS





TREVITECH s.r.l.

Via Tazio Nuvolari, 19

55012 Loc. Carraia - Capannori (Lu) - Italy

TEL. & FAX

T. +39 0583 490246

F. +39 0583 702006

E-MAIL

info@trevitech.it



www.trevitech.it



www.linkedin.com/company/trevitech-s-r-l

